

Path: \\gpc\p\external\office\Bourne\ECAD\SS\Hudson Brothers Ltd\PHILIPSTOWN99_PROJECTS\2017\7028 - PLANNING DRAWINGS\01\02_PRODUCTION\DWG | File Name: 013-16_SITE STRUCTURES.dwg

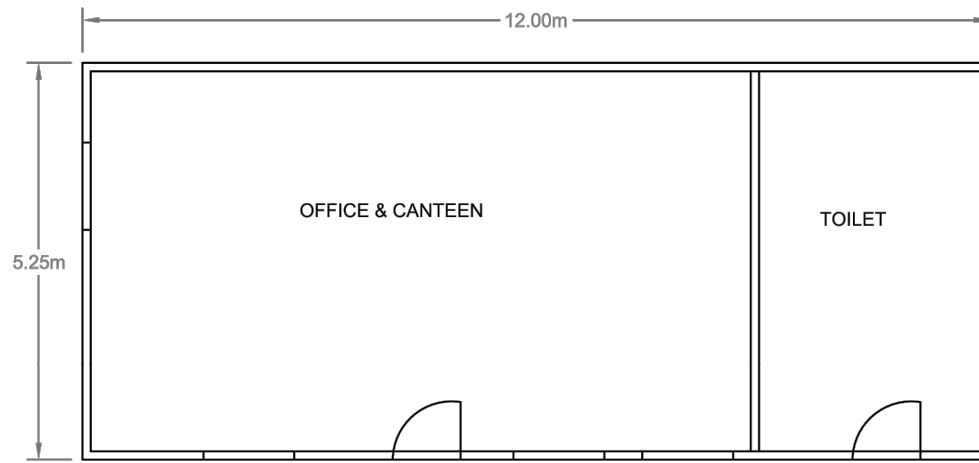

PERMANENT OFFICE & CANTEEN PLAN

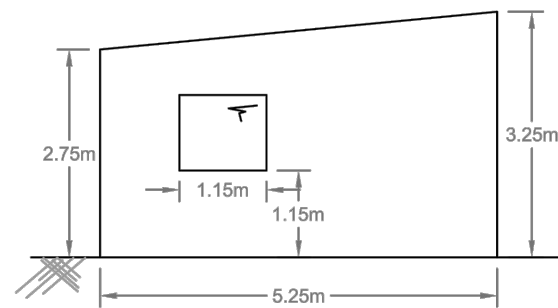

SIDE ELEVATION

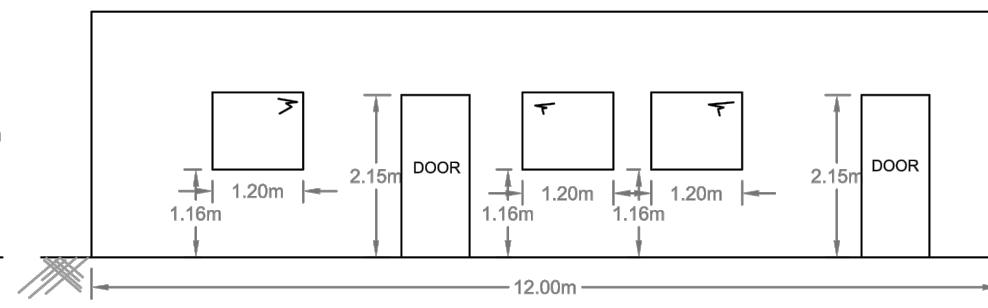

FRONT ELEVATION

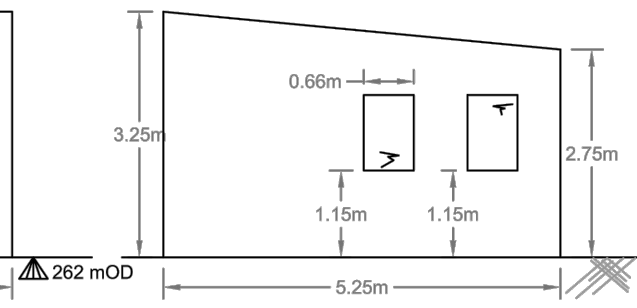

SIDE ELEVATION

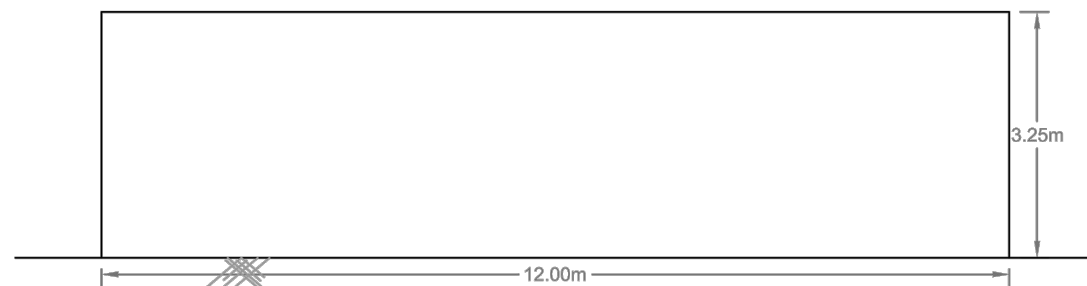

SECTION



CLIENT
HUDSON BROTHERS LTD

PROJECT
SUBSTITUTE CONSENT APPLICATION -
HUDSON BROTHERS LTD

CONSULTANT



YYYY-MM-DD	2024-02-06
PREPARED	KMG
DESIGN	ECS
REVIEW	KMG
APPROVED	KMG

TITLE
OFFICE AND CANTEEN

PROJECT No.
40000328

DRAWING No.
14

Rev.
A

SCALE
1:100 A3

25 mm IF THIS MEASUREMENT DOES NOT MATCH WHAT IS SHOWN, THE SHEET SIZE HAS BEEN MODIFIED FROM: ISO A3